

## ● HR 套筒式滚子链的附件

### ● A1 附件

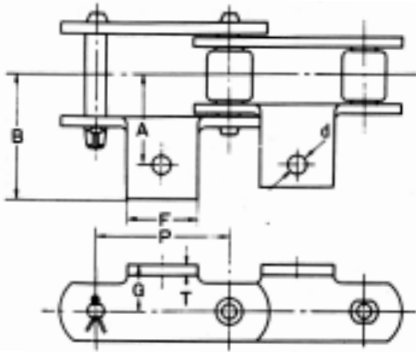

A1 附件尺寸图

#### ● A1 附件的尺寸

链号	节距 P (mm)	A (mm)	B (mm)	d (mm)	F (mm)	G (mm)	T (mm)	附加 重量 (kg/pc)
HR-6608	66.27	45	65	11	35	24	6.3	0.10
HR-7813	78.11	60	87	12	45	35	7.9	0.15

### ● A2 附件

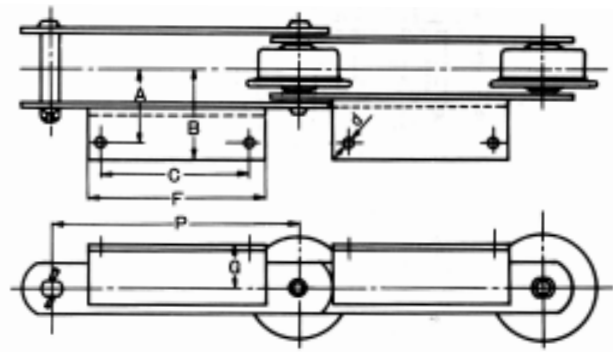

A2 附件尺寸图

#### ● A2 附件的尺寸

链号	节距 P (mm)	A (mm)	B (mm)	d (mm)	F (mm)	G (mm)	C (mm)	实用 角度 (mm)	附加 重量 (kg/pc)
HR-30019	300	75	110.5	15	220	45	180	L65 × 65 × 6	1.35
HR-30026	300	80	123.5	15	220	55	180	L75 × 75 × 9	2.20

### ● A2 附件

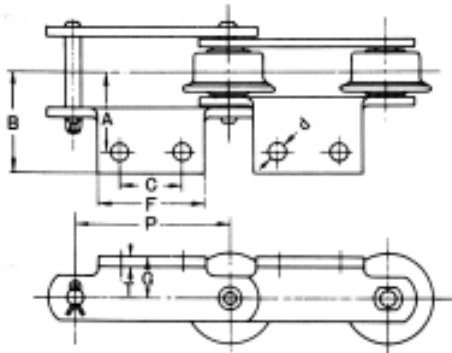

A2 附件尺寸图

#### ● A2 附件的尺寸

链号	节距 P (mm)	A (mm)	B (mm)	d (mm)	F (mm)	G (mm)	G (mm)	T (mm)	附加 重量 (kg/pc)
HR-7813	78.11	60	78.5	12	65	35	30	7.9	0.25
HR-10105	101.60	40	57.0	11	70	22	40	4.8	0.15
HR-10108	101.60	50	64.0	11	70	28	40	6.3	1.20
HR-10113	101.60	55	76.0	15	80	35	40	7.9	0.30
HR-15208	152.40	50	67.0	11	90	32	60	6.3	0.25
HR-15215	152.40	60	81.0	15	100	38	60	7.9	0.40
HR-15219	152.40	65	86.0	15	100	45	60	9.5	0.55
HR-10011	100.00	50	64.0	11	70	28	40	6.3	0.15
HR-15011	150.00	50	64.0	11	90	28	60	6.3	0.20
HR-20015	200.00	60	81.0	15	120	38	80	7.9	0.50
HR-20019	200.00	75	96.0	15	118	45	80	9.5	0.65
HR-25015	250.00	60	81.0	15	170	38	125	7.9	0.70
HR-25019	250.00	75	96.0	15	168	45	125	9.5	0.90

### ● A3 附件

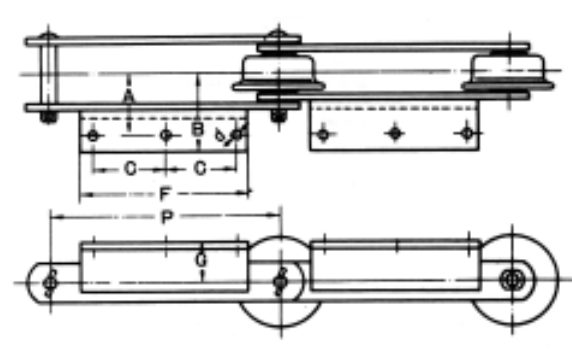

A3 附件尺寸图

#### ● A3 附件的尺寸

链号	节距 P (mm)	A (mm)	B (mm)	d (mm)	F (mm)	G (mm)	C (mm)	实用 角度 (mm)	附加 重量 (kg/pc)
HR-45026	450	80	123.5	15	320	55	140 × 2	L75 × 75 × 9	3.30
HR-45048	450	100	159.5	19	330	70	140 × 2	L100 × 100 × 10	5.10
HR-60048	600	100	159.5	19	410	70	180 × 2	L100 × 100 × 10	6.30

## ● K1 附件

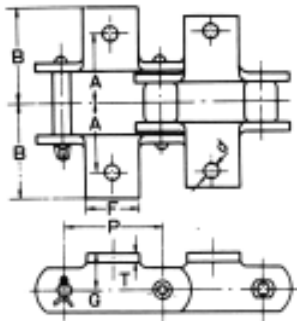

K1 附件尺寸图

### ● K1 附件的尺寸

链号	节距 P (mm)	2A (mm)	2B (mm)	d (mm)	F (mm)	G (mm)	T (mm)	附加重量 (kg/pc)
HR-6608	66.27	90	128	11	35	24	6.3	0.20
HR-7813	78.11	120	174	12	45	35	7.9	0.30

## ● K2 附件

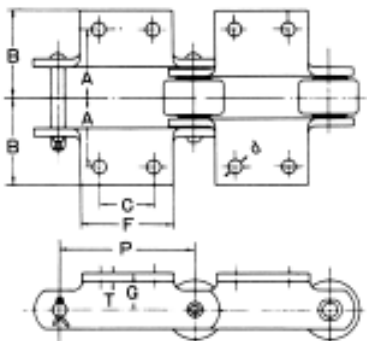

K2 附件尺寸图

### ● K2 附件的尺寸

链号	节距 P (mm)	2A (mm)	2B (mm)	d (mm)	F (mm)	G (mm)	C (mm)	T (mm)	附加重量 (kg/pc)
HR-10105	101.60	80	114	11	70	22	40	4.8	0.30
HR-10108	101.60	100	128	11	70	28	40	6.3	0.40
HR-10113	101.60	110	152	15	80	35	40	7.9	0.60
HR-15208	152.40	100	134	11	90	32	60	6.3	0.50
HR-15215	152.40	120	162	15	100	38	60	7.9	0.8
HR-15219	152.40	130	172	15	100	45	60	9.5	1.10
HR-10011	100.00	100	132	11	70	28	40	6.3	0.30
HR-15011	150.00	100	132	11	90	28	60	6.3	0.40

## ● G2 附件

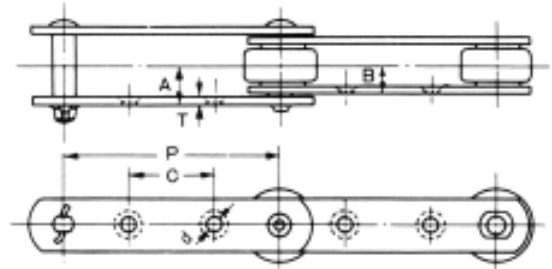

G2 附件尺寸图

### ● G2 附件的尺寸

链号	节距 P (mm)	A (mm)	B (mm)	d (mm)	C (mm)	T (mm)
HR-10105	101.60	20.9	15.8	9.5	45	4.8
HR-10108	101.60	26.5	19.8	11.0	35	6.3
HR-10113	101.60	32.0	23.4	11.0	35	7.9
HR-15208	152.40	28.1	21.3	11.0	60	6.3
HR-15215	152.40	35.0	26.5	15.0	50	7.9
HR-10011	100.00	28.1	21.3	11.0	35	6.3
HR-15011	150.00	28.1	21.3	11.0	60	6.3
HR-20015	200.00	35.0	26.5	15.0	80	7.9
HR-20019	200.00	45.5	35.0	15.0	70	9.5
HR-25015	250.00	35.0	26.5	15.0	125	7.9
HR-25019	250.00	45.5	35.0	15.0	110	9.5
HR-30019	300.00	45.5	35.0	15.0	150	9.5
HR-30026	300.00	48.5	38.0	15.0	240	9.5
HR-45026	450.00	48.5	38.0	15.0	220	9.5
HR-45048	450.00	59.5	46.0	19.0	220	12.7
HR-45054	450.00	71.5	54.5	22.0	220	16.0
HR-60048	600.00	59.5	46.0	19.0	300	12.7
HR-60054	600.00	71.5	54.5	22.0	300	16.0

## ● G4 附件

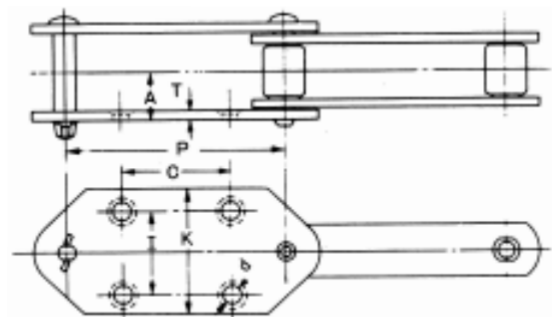

G4 附件尺寸图

### ● G4 附件的尺寸

链号	节距 P (mm)	A (mm)	d (mm)	C (mm)	T (mm)	I (mm)	K (mm)	附加重量 (kg/pc)
HR-15215	152.40	35.0	15	75	7.9	70	110	0.52
HR-15219	152.40	38.5	15	75	9.5	70	110	0.66
HR-20019	200.00	45.5	15	100	9.5	80	120	0.80
HR-25026	250.00	48.5	15	140	9.5	100	150	1.43