

用于制糖厂的英式链

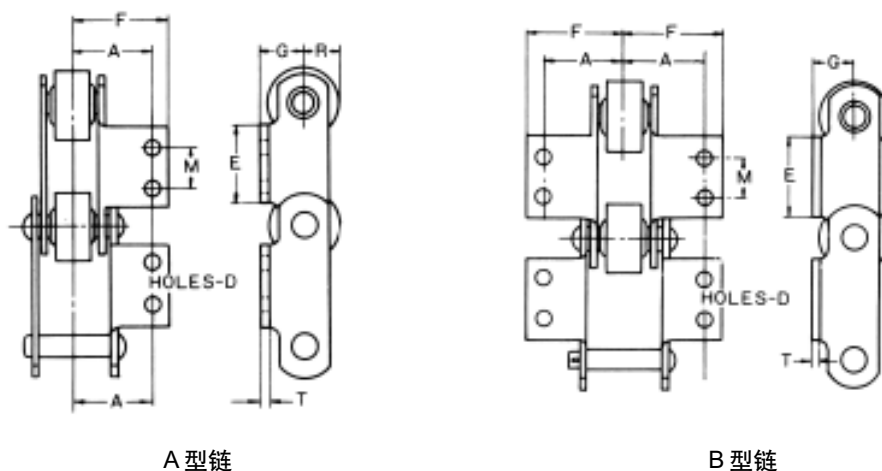

A 型链

B 型链

英式链的尺寸图

●英式链的尺寸与强度

链号	链型	节距 mm	滚子		销轴		联接板		平均极限强度 kg	重量 kg/m	可用附件号			
			D	W	d	L	H	T			A2	K2	AS2	AS20
			mm		mm		mm							
0904	A	101.6	50.8	29.4	17.5	79.4	44.5	7.9	18,150	16.07	○	○	○	○
0906	AB	152.4	69.9	36.5	19.0	95.3	50.8	9.5	18,150	16.67	○	○	○	○
09060	AB	152.4	69.9	36.5	19.0	95.3	50.8	9.5	27,200	16.67	○	○	○	○
09061	AB	152.4	69.9	36.5	19.0	95.3	57.2	9.5	38,600	17.86	○	-	○	-
SS600	B	152.4	69.9	36.5	22.2	100.0	58.4	9.5	45,400	只计附件重量	-	○	-	-
09063	A	152.4	76.2	36.5	22.8	101.6	61.9	10.3	63,500		-	○	-	-

链号	链型	节距 mm	滚子		销轴		联接板		平均极限强度 lbs	重量 lbs/ft.	可用附件号			
			D	W	d	L	H	T			A2	K2	AS2	AS20
			mm		mm		mm							
0904	A	4.00	2	1-5/32	11/16	3-1/8	1-3/4	5/16	40,000	10.8	○	○	○	○
0906	AB	6.00	2-3/4	1-7/16	3/4	3-3/4	2	3/8	40,000	11.2	○	○	○	○
09060	AB	6.00	2-3/4	1-7/16	3/4	3-3/4	2	3/8	60,000	11.2	○	○	○	○
09061	AB	6.00	2-3/4	1-7/16	3/4	3-3/4	2-1/4	3/8	85,000	12.0	○	-	○	-
SS600	B	6.00	2-3/4	1-7/16	7/8	3-15/16	2-5/16	3/8	100,000	只计附件重量	-	○	-	-
09063	A	6.00	3	1-7/16	15/16	4	2-7/16	13/32	140,000		-	○	-	-

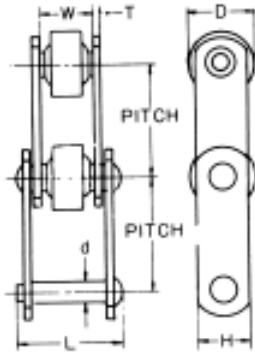

附件 A2

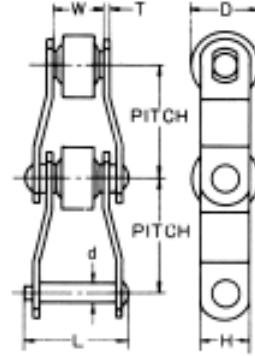

附件 K2

附件的尺寸图

●附件尺寸

(mm)

附件号	链号	重量 kg/m	A	D	E	F	G	M	T
			mm						
A2	0904	17.71	44.5	9.5	66.7	68.7	31.8	36.6	7.9
A2	0906	20.68	55.6	12.7	114.3	85.7	41.3	76.2	9.5
A2	09060	20.68	55.6	12.7	114.3	85.7	41.3	76.2	9.5
A2	09061	21.58	55.6	12.7	114.3	82.6	41.3	76.2	9.5
K2	0904	19.34	44.5	9.5	66.7	68.7	31.8	36.6	7.9
K2	0906	24.70	55.6	12.7	114.3	85.7	41.3	76.2	9.5
K2	09060	24.70	55.6	12.7	114.3	85.7	41.3	76.2	9.5
K2	09061	25.30	55.6	12.7	114.3	82.6	41.3	76.2	9.5
K2	09063	27.53	55.6	12.7	114.3	82.6	44.5	76.2	10.3
K2	SS600	20.83	55.6	12.7	111.1	73.0	41.3	76.2	9.5

(in.)

附件号	链号	重量 lbs/ft.	A	D	E	F	G	M	T
			in.						
A2	0904	11.9	1-3/4	3/8	2-5/8	1-45/64	1-1/4	1-7/16	5/16
A2	0906	13.9	2-3/16	1.2	4-1/2	3-3/8	1-5/8	3	3/8
A2	09060	13.9	2-3/16	1/2	4-1/2	3-3/8	1-5/8	3	3/8
A2	09061	14.5	2-3-16	1/2	4-1/2	3-1/4	1-5/8	3	3/8
K2	0904	13.0	1-3/4	3/8	2-5/8	2-15/64	1-1/4	1-7/16	5/16
K2	0906	16.6	2-3/16	1/2	4-1/2	3-3/8	1-5/8	3	3/8
K2	09060	16.6	2-3/16	1/2	4-1/2	3-3/8	1-5/8	3	3/8
K2	09061	17.0	2-3/16	1/2	4-1/2	3-1/4	1-5/8	3	3/8
K2	09063	18.5	2-3/16	1/2	4-1/2	3-1/4	1-3/4	3	13/32
K2	SS600	14.0	2-3/16	1/2	4-3/8	2-7/8	1-5/8	3	3/8

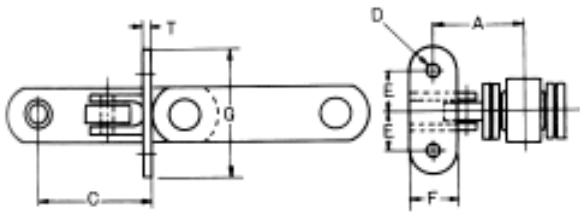

附件 AS2

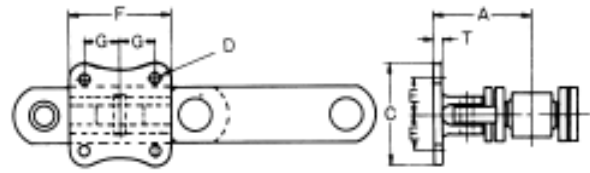

附件 AS20

附件的尺寸图

●附件尺寸

(mm)

附件号	链号	重量 kg/m	A	C	D	E	F	G	T
			mm						
AS2	0904	23.81	77.8	79.4	9.5	41.3	44.5	107.9	7.9
AS2	0906	23.06	88.9	111.1	12.7	41.3	50.8	114.3	7.9
AS2	09060	23.06	88.9	111.1	12.7	41.3	50.8	114.3	7.9
AS2	09061	29.02	88.9	111.1	12.7	41.3	50.8	114.3	7.9
AS20	0904	-	84.1	92.1	9.5	25.4	89.0	27.0	6.3
AS20	0906	-	104.8	108.0	12.7	38.1	95.3	31.8	7.9
AS20	09060	-	104.8	108.0	12.7	38.1	95.3	31.8	7.9

(in.)

附件号	链号	重量 lbs/ft.	A	C	D	E	F	G	T
			in.						
AS2	0904	16.0	3-1/16	3-1/8	3/8	1-5/8	1-3/4	4-1/4	5/16
AS2	0906	15.5	3-1/2	4-3/8	1/2	1-5/8	2	4-1/2	5/16
AS2	09060	15.5	3-1/2	4-3/8	1/2	1-5/8	2	4-1/2	5/16
AS2	09061	19.5	3-1/2	4-3/8	1/2	1-5/8	2	4-1/2	5/16
AS20	0904	-	3-5/16	3-5/8	3/8	1	3-1/2	1-1/16	1/4
AS20	0906	-	4-1/8	4-1/4	1/2	1-1/2	3-3/4	1-1/4	5/16
AS20	09060	-	4-1/8	4-1/4	1/2	1-1/2	3-3/4	1-1/4	5/16